

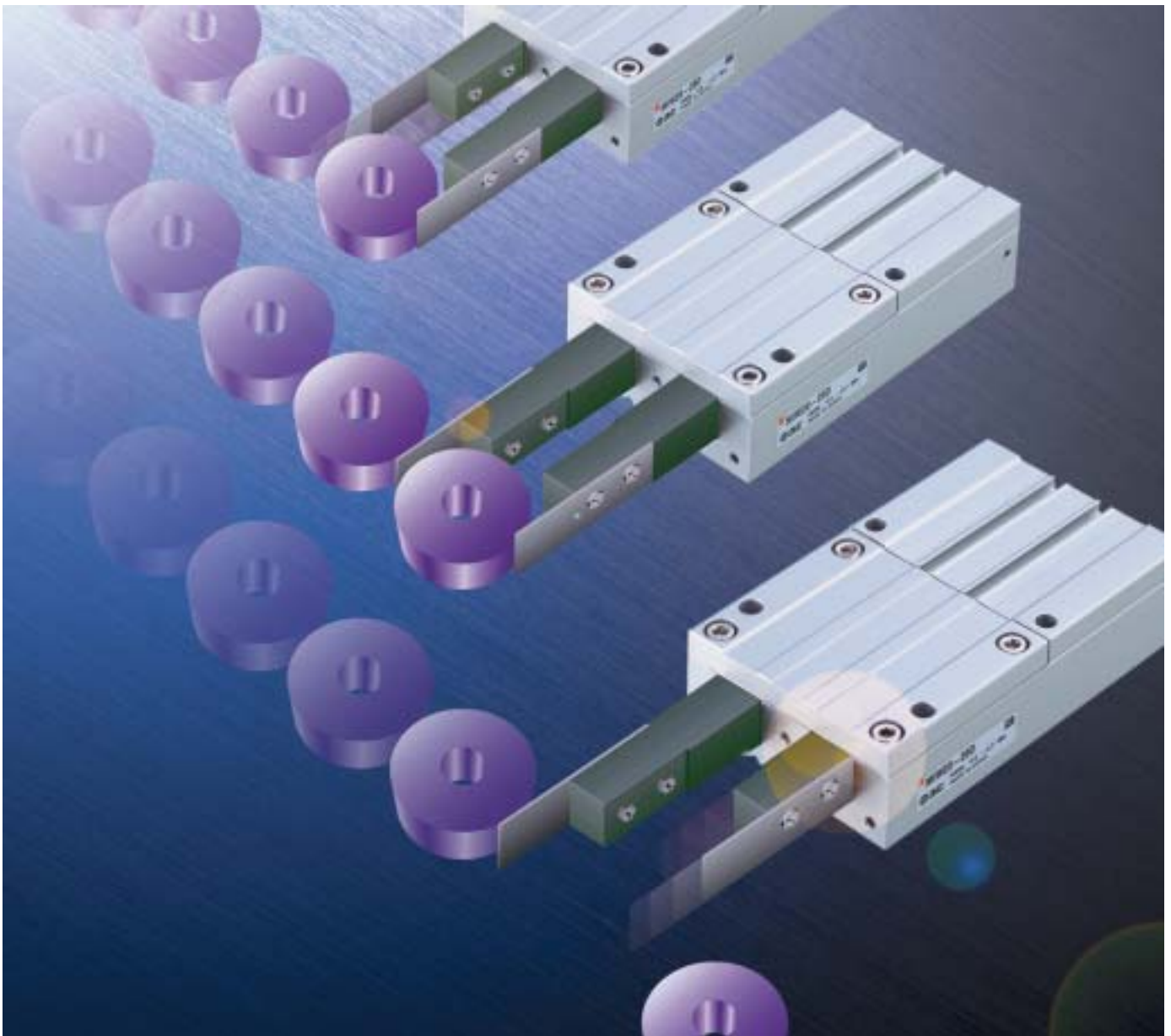

Escapements  
**Series MIW/MIS**  
ø12, ø20



Ideal for separating and feeding individual parts from vibratory feeders, magazines, and hoppers.

# Ideal for separating and from vibratory feeders,

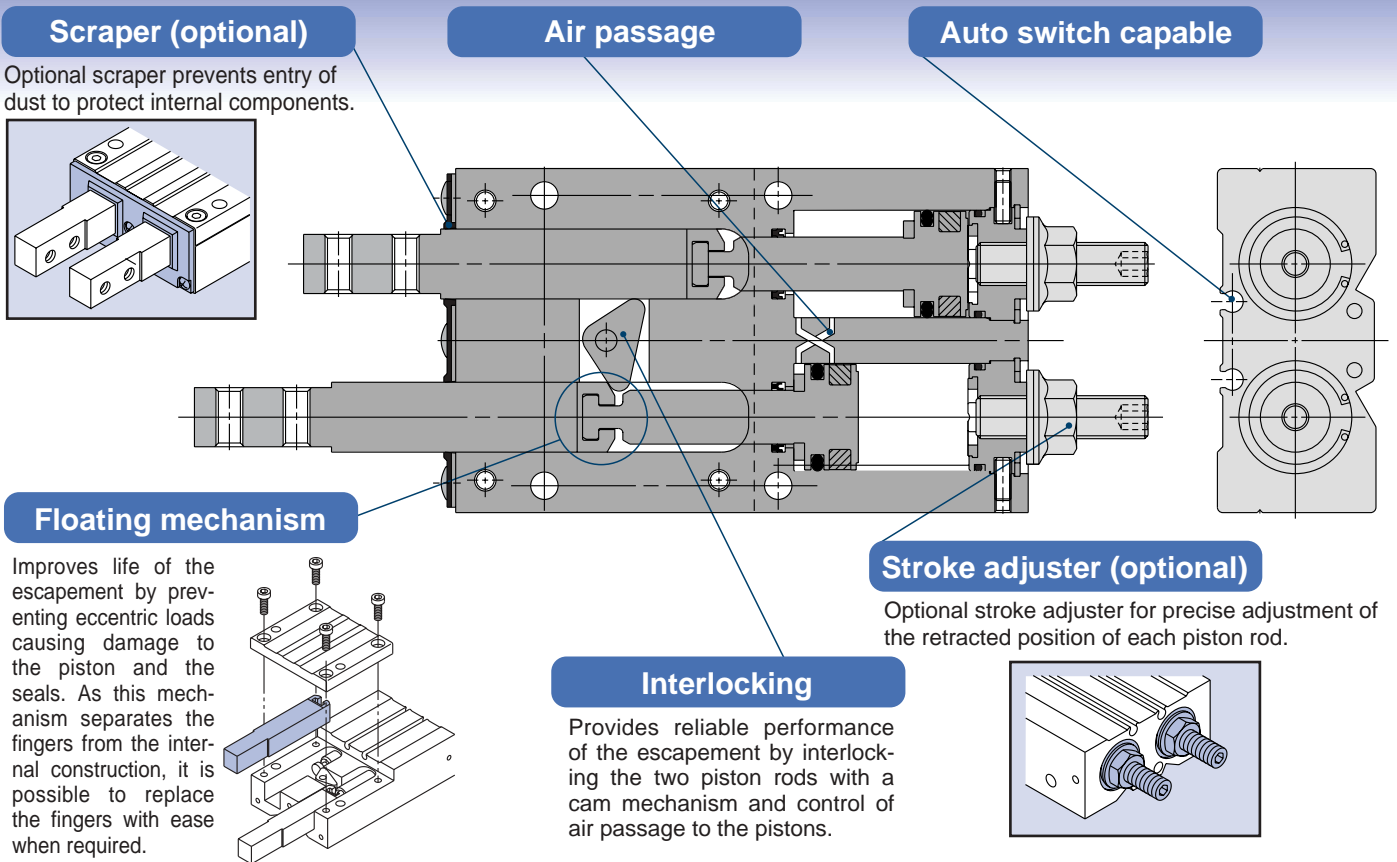

## Three variations of fingers

Flexibility in mounting the finger options.

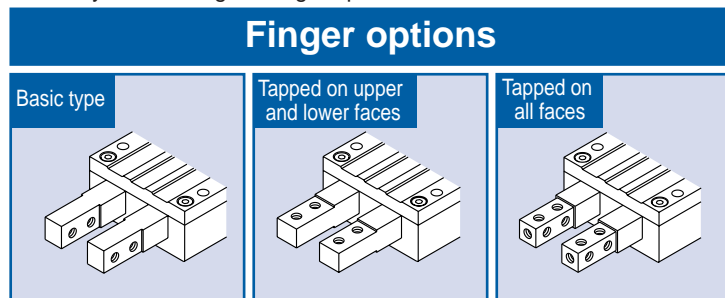

## Mounting is possible from 2 directions.

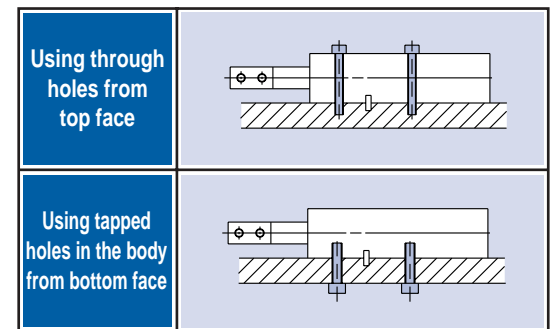

Positioning pin holes allow for easy mounting.

## Series variations

Series	Bore size mm	Stroke mm	Finger option	Stroke adjuster	Scraper
		10 12 20 30			
MIW	12	●	●	●	●
	20	●	●	●	●
MIS	12	●	●	●	●
	20	●	●	●	●

# feeding individual parts magazines, and hoppers.

## Application examples

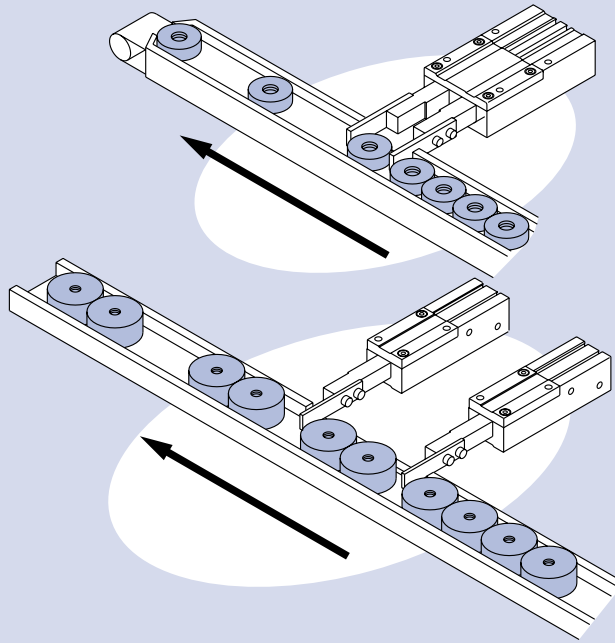

### MIW Double finger type

Single valve operation easily separates and feed each work piece.

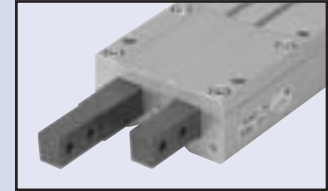

### MIS Single finger type

Operating speed and mounting position can be set according to the size of work piece and its operating condition.

Supply ports provided on both sides allow selection of piping direction.

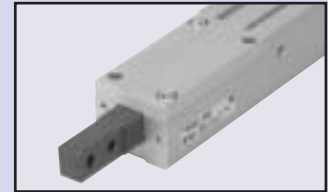

## Working principle

The cam locks Finger B.

When Finger A is extended to reach the stroke end, air is supplied to retract Finger B.

Extension of Finger A rotates the cam to unlock Finger B and lock finger A to allow retraction of Finger B.

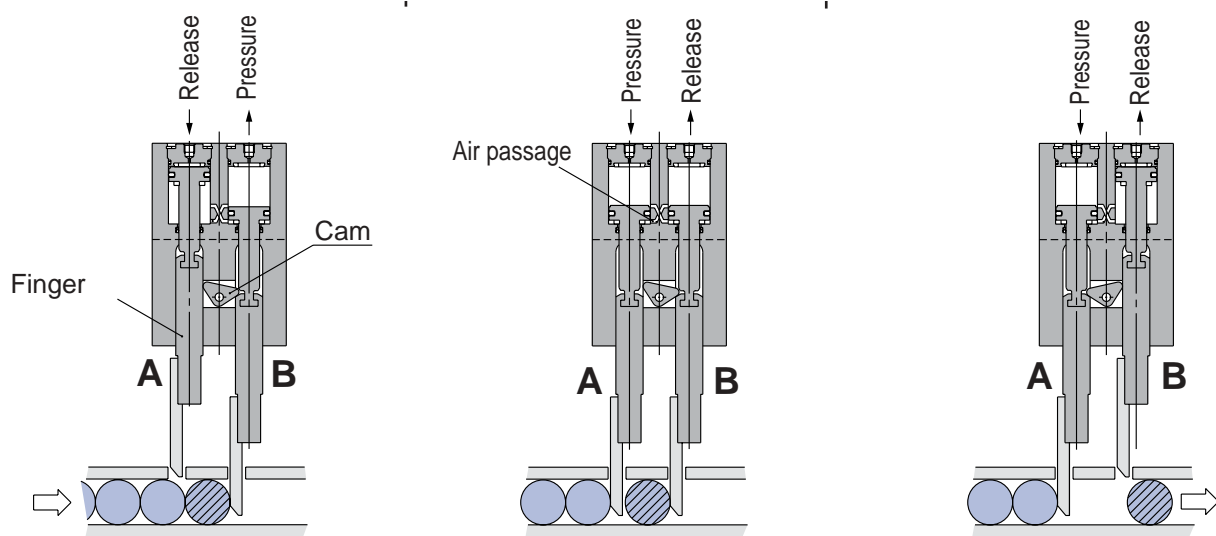

Insertion

Separation

Release





# Series MIW/MIS Model Selection

## Model Selection

### Selection procedure

Procedure1 Condition confirmation

Procedure2 Confirmation of impact by work piece

Procedure3 Confirmation of allowable lateral load

#### Procedure1 Confirmation of conditions

●The work piece moves horizontally on the conveyor.

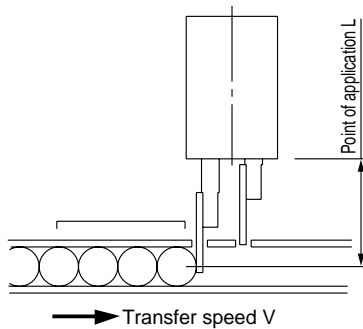

Operation conditions

Operating pressure P (MPa)

Work piece weight m (Kg)

Work piece quality x (Qty.)

Point of application L (mm)

Work piece transfer speed

V (m/min)

Coefficient of friction between the work piece and conveyor  $\mu$

●When the work piece drops vertically from a shooter, etc.

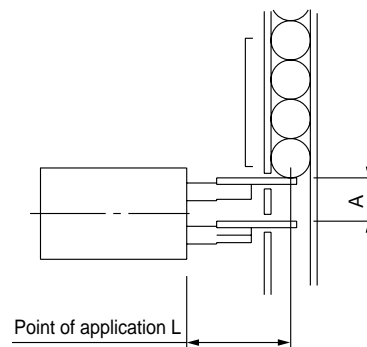

Operation conditions

Operating pressure P (MPa)

Work piece weight m (Kg)

Work piece quality x (Qty.)

Point of application L (mm)

Distance of work piece drop

H (m/min)

Gravitational acceleration g (m/s<sup>2</sup>)

#### Procedure2 Confirmation of impact

From the graph of operating range, obtain the point of intersection of the total weight of the work piece xm (kg) indicated by the axis of ordinates and the transfer speed V (m/min) indicated by the axis of abscissas. Select a model so that the intersection will fall below the point of application L indicated by a line.

1. Calculation of work piece collision speed

The collision speed V is calculated from the distance of work piece fall V.

$$\text{Work piece collision speed } V = \sqrt{2gH/1000} \times 60 \text{ (m/min)}$$

2. From the graph of operating range, obtain the intersection of the total weight of the work piece xm (kg) indicated by the axis of ordinates and the collision speed V (m/min) obtained by calculation. Select a model so that the intersection will fall below the point of application L indicated by a line.

#### Procedure3 Confirmation of allowable lateral load

1. Calculation of applied lateral load F

The lateral load F equals the coefficient between the work piece and the conveyor. Thus, from the total amount of the work piece and coefficient of friction,  $F = \mu \cdot x \cdot m \cdot g$  (N)

1. Calculation of applied lateral load

The lateral load F equals the total load of the work piece. Thus,  $F = x \cdot m \cdot g$  (N)

2. From the graph of allowable lateral load, obtain the allowable lateral load F max from the intersection of the operating pressure and the point of application L indicated by the axis of abscissas. Select a model so that the value will be larger than the lateral load F applied in real operation.



# Series MIW/MIS Model Selection

## Model Selection

### Operating range

Procedure1 Condition confirmation	
<p>●The work piece moves horizontally on the conveyor.</p> <p><b>Operating conditions</b></p> <p>Operating pressure                    <b>P = 0.4MPa</b>            Work piece weight                    <b>m = 0.1kg</b>            Work piece quantity                    <b>x = 10</b>            Point of application                    <b>L = 50mm</b>            Work piece transfer speed            <b>V = 12m/min</b>            Coefficient of friction between the work piece and conveyor <math>\mu = 0.2</math></p>	<p>●When the work piece drops vertically from a shooter, etc.</p> <p><b>Operating conditions</b></p> <p>Operating pressure                    <b>P = 0.4MPa</b>            Work piece weight                    <b>m = 0.05kg</b>            Work piece quantity                    <b>x = 5</b>            Point of application                    <b>L = 60mm</b>            Distance of work piece drop        <b>H = 15mm</b>            Gravitation acceleration            <b>g = 9.8m/s</b></p>
Procedure2 Confirmation of impact	
<p>· Obtain the total amount of the work piece.            Total weight <math>m = 10 \times 0.1</math> (kg) = 1 (kg)</p> <p>· Obtain the intersection of the transfer speed V and the total weight of work piece m. Confirm that the value is within the operating range of the point of application L = 50mm</p>	<p>· Obtain the total amount of the work piece.            Total weight <math>m = 5 \times 0.05</math> (kg) = 0.25 (kg)</p> <p>· Obtain the collision speed of the work piece V.</p> $V = \sqrt{2gH/1000 \times 60}$ $= \sqrt{2 \times 9.8 \times 15/1000 \times 60}$ $= 32.5 \text{ (m/min)}$ <p>· Obtain the intersection of the collision speed V and the total weight of the work piece m. Confirm that the value is within the operating range of the point of application L = 60mm.</p>
Procedure3 Confirmation of allowable lateral load	
<p>1. Calculation of applied lateral load F</p> $F = \mu \cdot N \cdot m \cdot g \text{ (N)}$ $= 0.2 \times 10 \times 0.1 \times 9.8$ $= 2.1 \text{ (N)}$ <p>2. Confirmation of allowable lateral load</p> <p>From the graph, the allowable lateral load at L=50mm and P=0.4MPa is 18N.</p> <p>Because <math>2.1N &lt; 18N</math>, it is applicable.</p>	<p><b>MIW12</b> <b>MIS12</b></p> <p>1. Calculation of applied lateral load</p> <p>The lateral load F equals the total load of the work piece. Thus,</p> $F = 5 \times 0.05 \times 9.8$ $= 2.5 \text{ (N)}$ <p>2. Confirmation of allowable lateral load</p> <p>In the same way, the lateral load at L=50mm and P=0.4MPa is 48N from the graph. Because <math>2.5N &lt; 48N</math>, it is applicable.</p>
<p>Therefore select MIW (MIS) 12.</p>	<p>Therefore select MIW (MIS) 20.</p>

**Operating range**

The graph at right shows conditions of the work piece to be stopped; that is, the weight, transfer speed and the operating range of the point of application L.

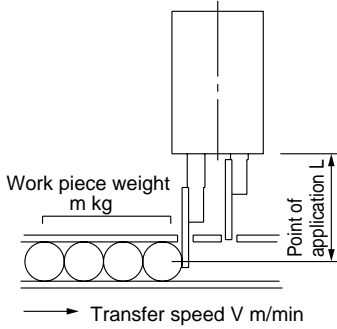

**MIW12  
MIS12**

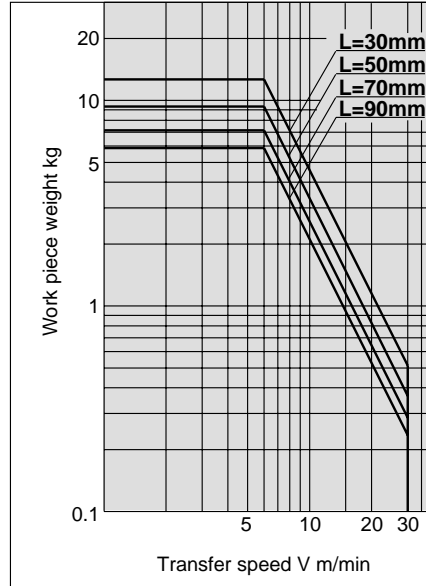

**MIW20  
MIS20**

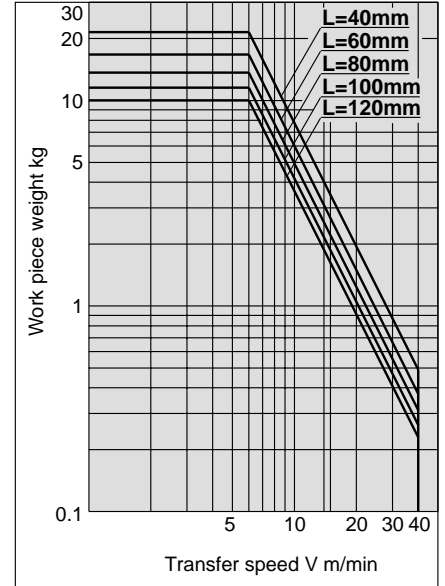

**Allowable lateral load**

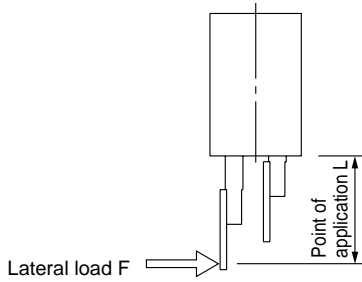

**MIW12  
MIS12**

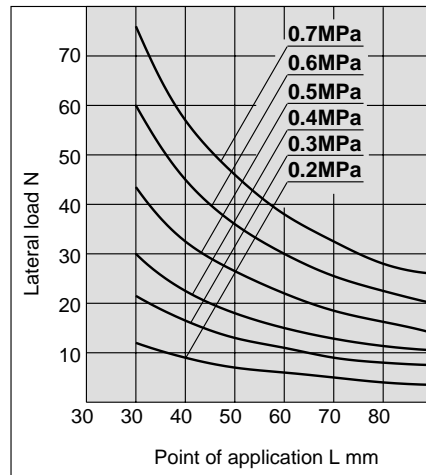

**MIW20  
MIS20**

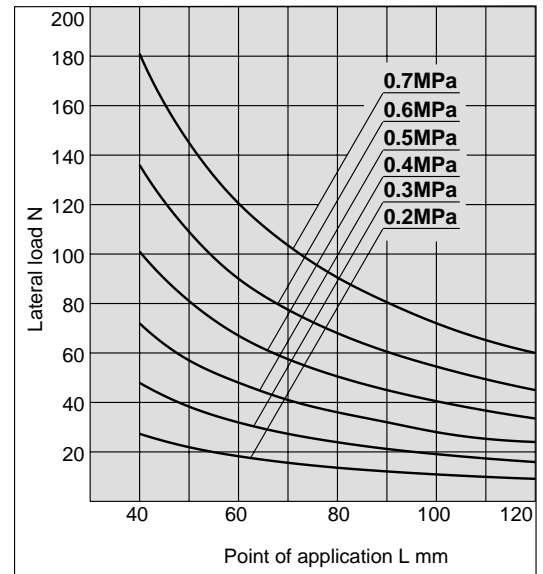

# Escapements

# Series MIW/MIS

ø12, ø20

## How to Order

**Stroke**

ø12	12	12mm
ø20	20	20mm

\*MIW only accommodates a stroke of the same length as the cylinder diameter.

**Finger options**

Nil: Basic type (Standard type)	1: Tapped on upper and lower faces	2: Tapped on all faces (5 surfaces including end surface)
---------------------------------	------------------------------------	---

**Double finger type** MIW 12-12 D 1 A S - F9NV S

**Single finger type** MIS 20-30 D 1 A S - F9BV S

**Cylinder bore**

12	12mm
20	20mm

**Stroke**

10	10mm
20	20mm
30	30mm

**Scraper**

Nil	No
S	Yes

**Stroke adjuster**

Nil	No
A	Yes

**Number of auto switches**

Nil	2 pcs.
S	1 pc.

**Type of auto switch**

Nil	Without auto switch (built-in magnet)
-----	---------------------------------------

\*Refer to the table below for auto switch part numbers.

**Finger options**

Nil: Basic type (Standard type)	1: Tapped on upper and lower faces	2: Tapped on all faces (5 surfaces including end surface)
---------------------------------	------------------------------------	---

**Applicable auto switches/**Refer to pages 14 through 18 for detailed specifications of auto switches.

Type	Special function	Electrical entry	Indicator light	Wiring (output)	Load voltage		Auto switch model		Lead wire length (m) *			Flexible lead wire (-X61)	Applicable load		
					DC	AC	Electrical entry direction		0.5 (Nil)	3 (L)	5 (Z)				
Solid state (switch)	—	Grommet	Yes	3-wire (NPN)	24V	12V	—	F9NV	F9N	●	●	—	○	Relay PLC	
								F8N	—	●	●	○	○		
								F9PV	F9P	●	●	—	○		
								F8P	—	●	●	○	○		
								F9BV	F9B	●	●	—	○		
								F8B	—	●	●	○	○		
	Diagnostic indication (2-color display)	Grommet	Yes	3-wire (NPN)	24V	12V	—	—	F9NWV	F9NW	●	●	○		○
									F9PWV	F9PW	●	●	○		○
									F9BWB	F9BW	●	●	○		○
									F9BWB	F9BW	●	●	○		○

\*Lead wire length symbols: 0.5m..... Nil (Example) F9N

3m..... L (Example) F9NL

5m..... Z (Example) F9NZ

\*Auto switches marked with a "○" symbol are produced upon receipt of order.

## Specifications

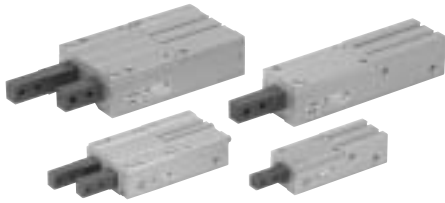

Series	MIW (Double finger)	MIS (Single finger)
Fluid	Air	
Operating pressure	0.2 to 0.7MPa	
Ambient temperature and fluid temperature	- 10 to 60°C	
Lubrication	Non-lube	
Action	Double acting	
Auto switch (optional) <sup>Note)</sup>	Solid state switch (3-wire, 2-wire)	
Stroke length tolerance	+ <sup>1</sup> / <sub>0</sub> mm	

Note) Refer to pages 14 through 18 for auto switch specification.

## Options

Finger options	Standard, Tapped on upper and lower faces, Tapped on all faces (5 surfaces including end surface)
Stroke adjuster (Rear end stroke only)	MI□12: Arrangement range 6mm MI□20: Arrangement range 12mm
Scraper	Can be mounted on standard products

## Theoretical Outputs

Unit: N

Bore size (mm)	Rod size (mm)	Operating direction	Piston area (mm <sup>2</sup> )	Operating pressure MPa					
				0.2	0.3	0.4	0.5	0.6	0.7
12	6	OUT	113	23	34	45	57	68	79
		IN	85	17	26	34	43	51	60
20	10	OUT	314	63	94	126	157	188	220
		IN	236	47	71	94	118	142	165

## Weights

Unit: g

Model	Model	Stroke mm	Weight g	Increase by stroke adjuster	Increase by scraper
MIW	MIW12-12D	12	240	10	5
	MIW20-20D	20	650	30	10
MIS	MIS12-10D	10	130	5	3
	MIS12-20D	20	160		
	MIS12-30D	30	190		
	MIS20-10D	10	300	15	5
	MIS20-20D	20	355		
	MIS20-30D	30	410		

# Series MIW/MIS

## Construction

### Double finger type/MIW

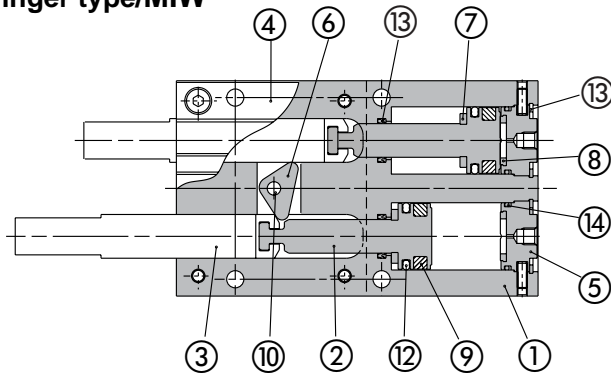

### Option

#### With scraper

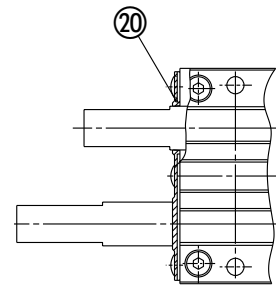

### Single finger type/MIS

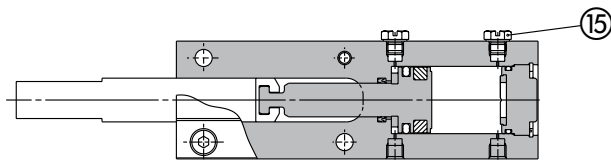

#### With stroke adjuster

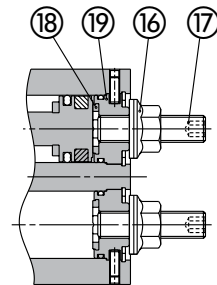

### Parts list: Standard

No.	Description	Material	Note
1	Body	Aluminium alloy	Hard anodized
2	Piston	Stainless steel	
3	Finger	Carbon steel	Heat treatment/Special treatment
4	Cover	Aluminium alloy	Hard anodized
5	Cap	Aluminium alloy	White anodized
6	Cam	Stainless steel	Heat treatment, For MIW only
7	Bumper	Urethane rubber	
8	Head bumper	Urethane rubber	
9	Rubber magnet	Synthetic rubber	
10	Needle roller	High carbon chromium bearing steel	For MIW only
11	R shape snap ring	Carbon steel	
12	Piston seal	NBR	
13	Rod seal	NBR	
14	Gasket	NBR	Nickel plated
15	Plug		M-5P, For MIS only

### Parts list: Option/With stroke adjuster

No.	Description	Material	Note
16	Hexagon nut with flange	Carbon steel	Nickel plated
17	Adjustment bolt	Carbon steel	Nickel plated
18	Adjustment bumper	Urethane rubber	
19	Adjustment cap	Aluminium alloy	Clear anodized

### Parts list: option/With stroke scraper

No.	Description	Material	Note
20	Scraper	Stainless steel + NBR	

### Replacement parts/MIW

Description	Part no.		Kit components	
	MIW12-12D	MIW20-20D		
Finger	Standard	MI-A1201-12	MI-A2001-20	3
	Tapped on upper and lower faces	MI-A1202-12	MI-A2002-20	
	Tapped on all faces	MI-A1203-12	MI-A2003-20	
Seal kit (NBR)		MIW12-PS	MIW20-PS	12
				13
				14
Scraper assembly	MIW-A1204	MIW-A2004	20	
Grease pack	MH-G01 (contents quantity 30g)		—	

### Replacement parts/MIS

Description	Order no.							Kit components
	MIS12-10D	MIS12-20D	MIS12-30D	MIS20-10D	MIS20-20D	MIS20-30D		
Finger	Standard	MI-A1201-10	MI-A1201-20	MI-A1201-30	MI-A2001-10	MI-A2001-20	MI-A2001-30	3
	Tapped on upper and lower faces	MI-A1202-10	MI-A1202-20	MI-A1202-30	MI-A2002-10	MI-A2002-20	MI-A2002-30	
	Tapped on all faces	MI-A1203-10	MI-A1203-20	MI-A1203-30	MI-A2003-10	MI-A2003-20	MI-A2003-30	
Seal kit (NBR)	MIS12-PS			MIS20-PS			12	
							13	
							14	
Scraper assembly	MIS-A1204			MIS-A2004			20	
Grease pack	MH-G01 (contents quantity 30g)							—

**Dimensions**

MIW□-□D

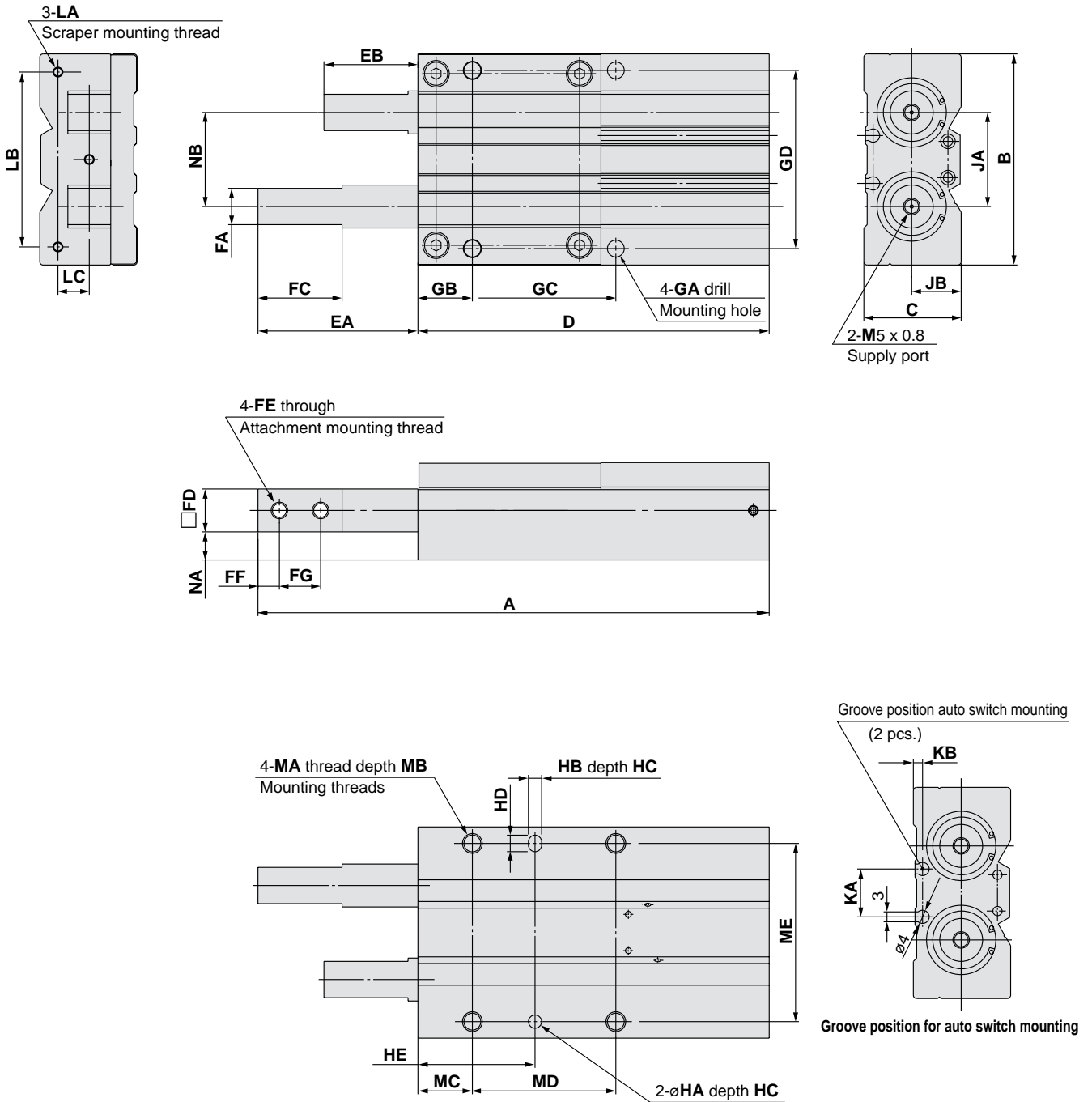

Model	A	B	C	D	EA	EB	FA	FB	FC	FD	FE	FF	FG	FH	GA	GB	GC	GD
MIW12-12	111	44	21	76	35	23	8	8	19	10	M3 x 0.5	4.5	9.5	6 (Effective depth 3)	3.3	12.5	34	37
MIW20-20	155	64	29.5	106.5	48.5	28.5	11	11	25.5	13	M5 x 0.8	6.5	12.5	10 (Effective depth 4)	5.1	16.5	43.5	54
Model	HA, HB	HC	HD	HE	JA	JB	KA	KB	LA	LB	LC	MA	MB	MC	MD	ME	NAB	NB
MIW12-12	2.5H9 <sup>+0.025</sup> <sub>0</sub>	4	3.5	25	19	11	7.6	2.2	M2.6x0.45	37	7.5	M4 x 0.7	6	12.5	34	37	6	19
MIW20-20	4H9 <sup>+0.030</sup> <sub>0</sub>	5	5	35.5	28.5	15	14.5	2.8	M3x0.5	53	9.5	M6 x 1	9	16.5	43.5	54	8.5	28.5

## Finger options

### Tapped on upper and lower faces

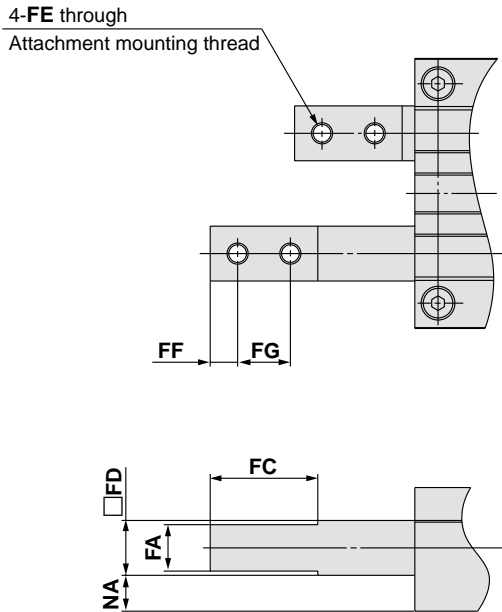

### Tapped on all faces

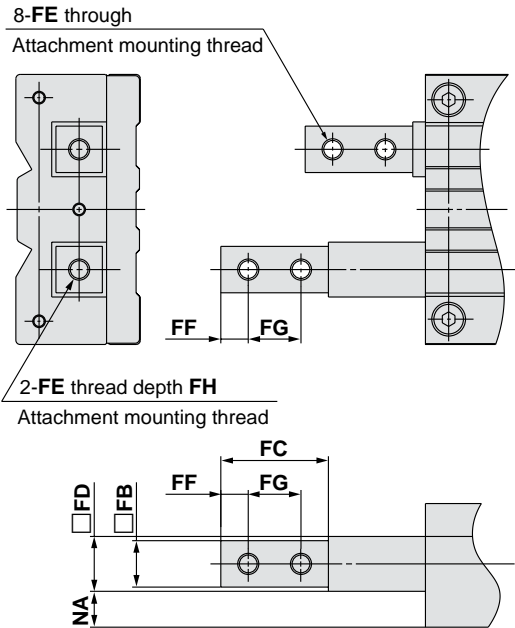

## Stroke adjuster

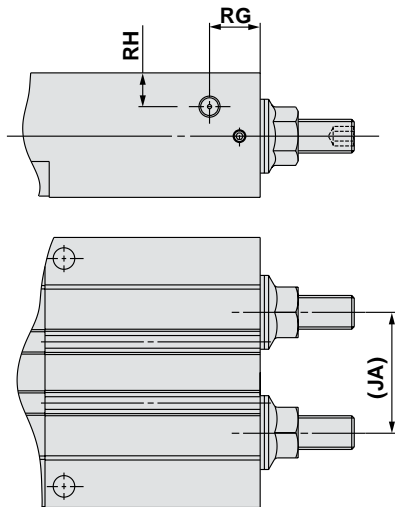

## Scraper

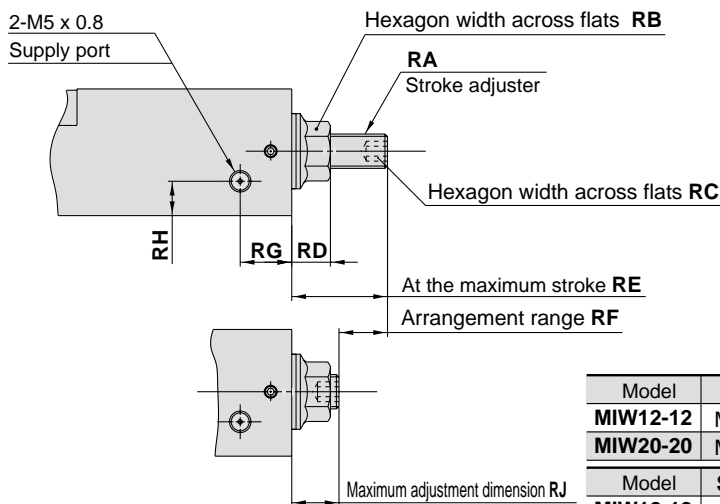
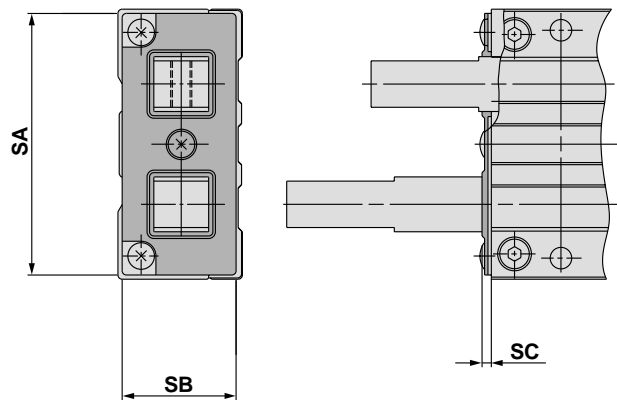

Model	RA	RB	RC	RD	RE	RF	RG	RH	RJ	
<b>MIW12-12</b>	M5 x 0.8	8	2.5	6	14	6	10	6	8	
<b>MIW20-20</b>	M8 x 1	12	4	9	22.5	12	12	8	10.5	
Model	SA	SB	SC							
<b>MIW12-12</b>	43	18.5	1.8							
<b>MIW20-20</b>	62	27	2.2							

Note) Observe the specified adjustment range when adjusting with a stroke adjuster.

**Dimensions**

MIS□-□D

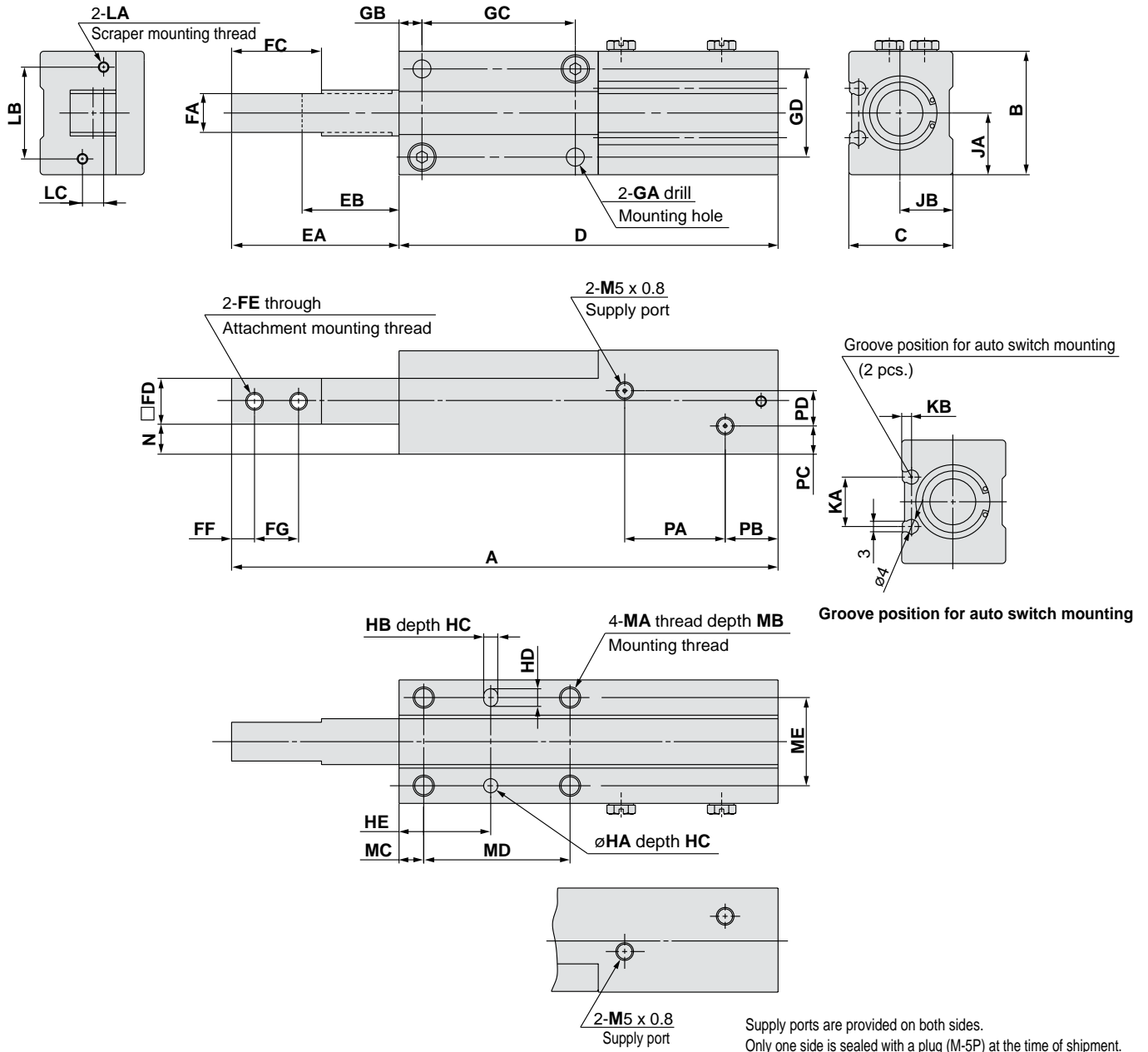

Model	A	B	C	D	EA	EB	FA	FB	FC	FD	FE	FF	FG	FH	GA	GB	GC	GD	
MIS12-10	105	26	21	72	33	23	8 <sup>0</sup> <sub>-0.1</sub>	8 <sup>0</sup> <sub>-0.1</sub>	19	10	M3 x 0.5	4.5	9.5	6 (Effective depth 3)	3.3	5	28	18	
MIS12-20	135			92	43														38
MIS12-30	165			112	53														48
MIS20-10	125	35	29.5	86.5	38.5	28.5	11 <sup>0</sup> <sub>-0.1</sub>	11 <sup>0</sup> <sub>-0.1</sub>	25.5	13	M5 x 0.8	6.5	12.5	10 (Effective depth 4)	5.1	7	32	25	
MIS20-20	155			106.5	48.5														42
MIS20-30	185			126.5	58.5														52

Model	HA, HB	HC	HD	HE	JA	JB	KA	KB	LA	LB	LC	MA	MB	MC	MD	ME	N	PA	PB	PC	PD
MIS12-10	∅2.5H9 <sup>+0.025</sup> <sub>0</sub>	4	3.5	17.5	13	11	11.6	2.3	M2.6 x 0.45	19	4	M4 x 0.7	6	5	28	18	6	19	10	6	7
MIS12-20															38			29			
MIS12-30															48			39			
MIS20-10	∅4H9 <sup>+0.030</sup> <sub>0</sub>	5	5	26	17.5	15	14	2.8	M3 x 0.5	26	6	M6 x 1	9	7	32	25	8.5	20.5	12	8	10
MIS20-20															42			30.5			
MIS20-30															52			40.5			

# Series MIW/MIS

## Finger options

### Tapped on upper and lower faces

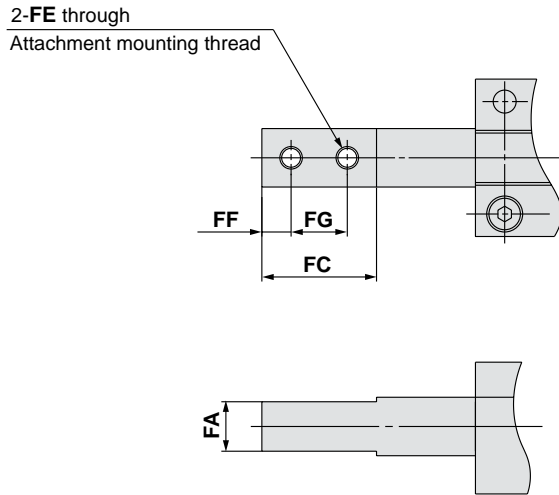

### Tapped on all faces

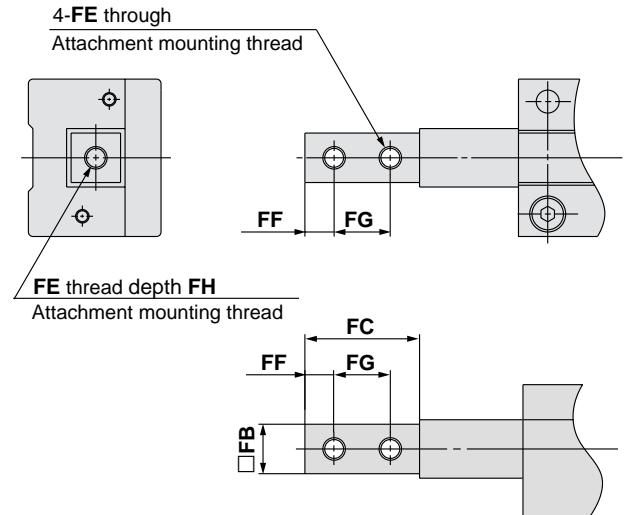

### With adjuster

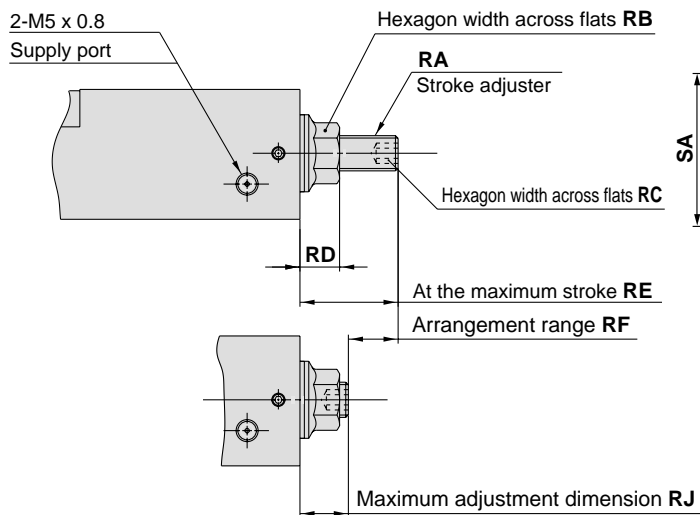

### With scraper

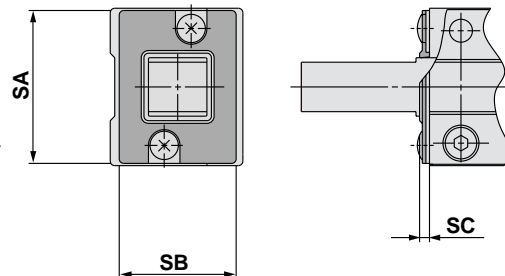

Note) Observe the specified adjustment range when adjusting with a stroke adjuster.

Model	RA	RB	RC	RD	RE	RF	RJ	SA	SB	SC
<b>MIS12-10</b>										
<b>MIS12-20</b>	M5 x 0.8	8	2.5	6	14	6	8	24	18	1.8
<b>MIS12-30</b>										
<b>MIS20-10</b>										
<b>MIS20-20</b>	M8 x 1	12	4	9	22.5	12	10.5	34	26	2.2
<b>MIS20-30</b>										



## Auto Switch Mounting

When mounting an auto switch, insert the switch in the switch mounting groove on the escapement from the bottom. Having set the mounting position, tighten the attached switch mounting screws with a flat head watchmakers screw driver.

\*When adjusting the auto switch mounting screws, use a flat head watchmakers screw driver.

(This is to prevent fracture due to an excessive torque.)

The guideline of the tightening torque is 0.05 to 0.1Nm.

Turn another 90° from the position where tightening is felt by hand.

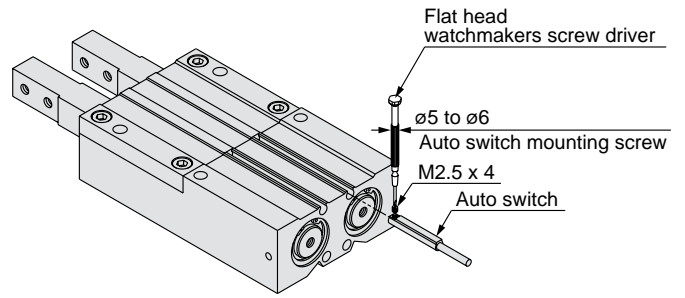

## Proper mounting position for stroke end detection

Model	Electrical entry is in the → direction	Electrical entry is in the ← direction
F9□(V) F9□W(V)		
F8□		

(mm)

Model	Proper mounting position			Sensitivity range	Model	Proper mounting position			Sensitivity range
	D-F9□ D-F9□W	D-F9□V D-F9□WV	D-F8□			D-F9□ D-F9□W	D-F9□V D-F9□WV	D-F8□	
MIW12-12D	A	18.5	20.5	2.5	MIW20-20D	A	20.5	22.5	4
	B	31	33			B	41	43	
	C	6.5	4.5			C	8.5	6.5	
	D	—	17			D	—	27	
	E	6	4			—	E	4	
MIS12-10D	A	18.5	20.5		MIS20-10D	A	20.5	22.5	
	B	29	31			B	31	33	
	C	6.5	4.5			C	8.5	6.5	
	D	—	15			D	—	17	
	E	6	4			—	E	4	
MIS12-20D	A	18.5	20.5	MIS20-20D	A	20.5	22.5		
	B	39	41		B	41	43		
	C	6.5	4.5		C	8.5	6.5		
	D	—	15		D	—	27		
	E	6	4		—	E	4	2	
MIS12-30D	A	18.5	20.5	MIS20-30D	A	20.5	22.5		
	B	49	51		B	51	53		
	C	6.5	4.5		C	8.5	6.5		
	D	—	35		D	—	37		
	E	6	4		—	E	4	2	

# Series MIW/MIS Auto Switch Common Specifications

## Auto Switch Common Specifications

Type	Solid state switch
Operating time	1ms or less
Impact resistance	1000m/s <sup>2</sup>
Insulation resistance	50MΩ or more at 500VDC (between lead wire and case)
Withstand voltage	1000VAC for 1 min. (between lead wire and case)
Ambient temperature	-10 to 60°C
Enclosure	IEC529 standard IP67 JISC0920 watertight construction

## Lead Wire Lengths

### Lead wire length indication

(Example)

**D-F9P** **L**

• Lead wire length

Nil	0.5m
L	3m
Z	5m

- Note 1) Lead wire length Z: Auto switch applicable to 5m length  
Solid state switches: All models produced upon receipt of order (standard procedure).
- Note 2) The water resistant 2-color solid state switch uses a 3 m lead wire as standard.  
(0.5 m is not available.)
- Note 3) For solid state with flexible wire specification, add "-61" after the lead wire length.

(Example) **D-F9PL-61**

• Flexible specification

## Lead Wire Color Changes

Lead wire colors of SMC auto switches have been changed as shown in the tables below starting from production in September 1996, in order to meet the IEC947-5-2 standard.

Take special care regarding wire polarity during the time when the old colors still coexist with the new colors.

### 2-wire

	Old	New
Output (+)	Red	Brown
Output (-)	Black	Blue

### 3-wire

	Old	New
Power supply +	Red	Brown
Power supply GND	Black	Blue
Output	White	Black

### Solid state with diagnostic output

	Old	New
Power supply +	Red	Brown
Power supply GND	Black	Blue
Output	White	Black
Diagnostic output	Yellow	Orange

### Solid state with latch type diagnostic output

	Old	New
Power supply +	Red	Brown
Power supply GND	Black	Blue
Output	White	Black
Latch type diagnostic output	Yellow	Orange

# Series MIW/MIS

## Auto Switch Connections and Examples

### Basic Wiring

#### Solid state 3-wire, NPN

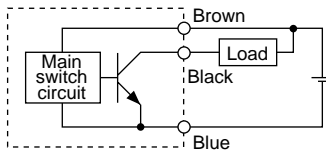

(Power supplies for switch and load are separate.)

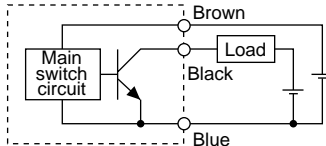

#### Solid state 3-wire, PNP

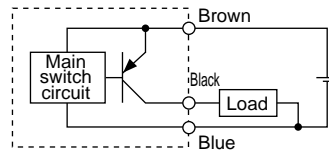

#### 2-wire <Solid state>

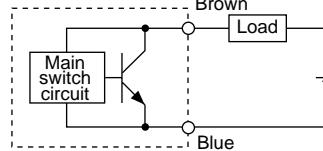

#### 2-wire <Reed switch>

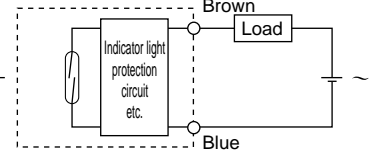

### Examples of Connection to PLC

#### Sink input specification 3-wire, NPN

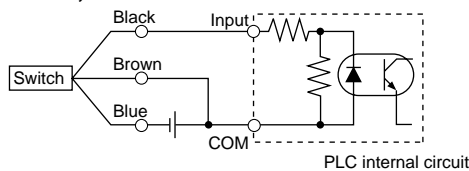

#### Source input specification 3-wire, PNP

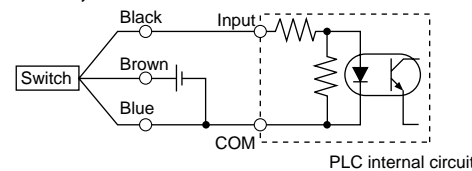

Connect according to the applicable PLC input specifications, as the connection method will vary depending on the PLC input specifications.

#### 2-wire

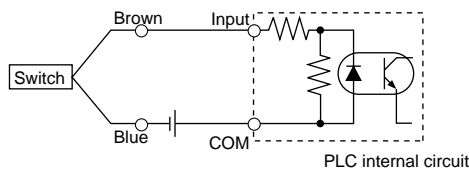

#### 2-wire

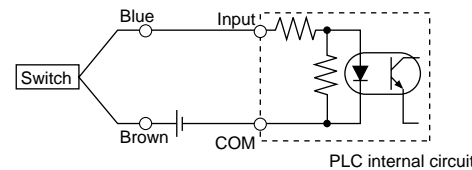

### Connection Examples for AND (Series) OR (Parallel)

#### 3-wire

##### AND connection for NPN output (using relays)

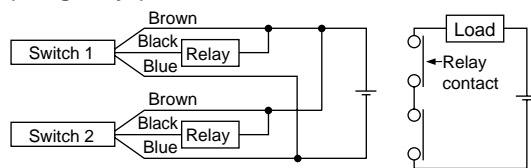

##### AND connection for NPN output (performed with switches only)

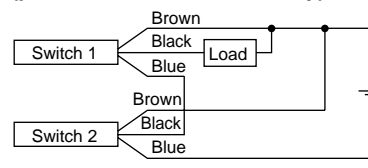

##### OR connection for NPN output

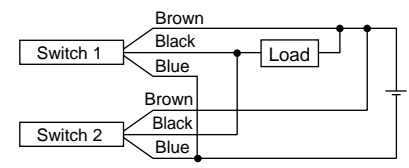

The indicator lights will light up when both switches are turned ON.

#### 2-wire with 2 switch AND connection

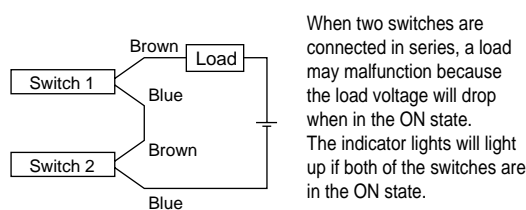

When two switches are connected in series, a load may malfunction because the load voltage will drop when in the ON state. The indicator lights will light up if both of the switches are in the ON state.

$$\begin{aligned} \text{Load voltage at ON} &= \text{Power supply voltage} - \text{Voltage drop} \times 2 \text{ pcs.} \\ &= 24\text{V} - 4\text{V} \times 2 \text{ pcs.} \\ &= 16\text{V} \end{aligned}$$

Example: Power supply is 24VDC  
Voltage drop in switch is 4V

#### 2-wire with 2 switch OR connection

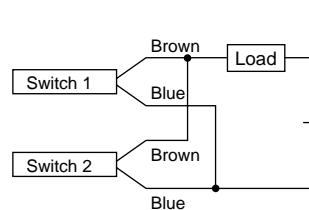

##### <Solid state switch>

When two switches are connected in parallel, malfunction may occur because the load voltage will increase when in the OFF state.

##### <Reed switch>

Because there is no current leakage, the load voltage will not increase when turned OFF. However, depending on the number of switches in the ON state, the indicator lights may sometimes get dark or not light up, because of dispersion and reduction of the current flowing to the switches.

$$\begin{aligned} \text{Load voltage at OFF} &= \text{Leakage current} \times 2 \text{ pcs.} \times \text{Load impedance} \\ &= 1\text{mA} \times 2 \text{ pcs.} \times 3\text{k}\Omega \\ &= 6\text{V} \end{aligned}$$

Example: Load impedance is 3kΩ  
Leakage current from switch is 1mA

# Solid State Switches/Direct Mount Type D-F8N, D-F8P, D-F8B

## Grommet



## ⚠ Caution

### Operation Instructions

Be sure to use the attached fixing screws to secure the auto switch.  
Use of screws beyond the specified range can damage the switch.

## Auto Switch Specifications

Auto switch part no.	D-F8N	D-F8P	D-F8B
Electrical entry direction	Perpendicular	Perpendicular	Perpendicular
Wiring type	3-wire		2-wire
Output type	NPN	PNP	—
Applicable load	IC circuit, 24VDC relay, PLC		24VDC relay, PLC
Power supply voltage	5, 12, 24VDC (4.5 to 28V)		—
Current consumption	10mA or less		—
Bad voltage	28VDC or less	—	24V DC (10 to 28V)
Bad current	40mA or less	80mA or less	2.5 to 40mA
Internal voltage drop	1.5V or less (0.8V or less at 10mA load current)	0.8V or less	4V or less
Leakage current	100 $\mu$ A or less at 24VDC		0.8mA or less at 24VDC
Indicator light	Red LED light when ON		

● Lead wire — Heavy duty oil resistant vinyl cord,  $\phi$ 2.7, 0.5m

D-F8N, D-F8P 0.15mm<sup>2</sup> x 3 wire (Brown, Black, Blue)

D-F8B 0.18mm<sup>2</sup> x 2 wire (Brown, Blue)

Note 1) Refer to page 14 for auto switch common specifications.

Note 2) Refer to page 14 for lead wire lengths.

## Auto Switch Internal Circuits

### D-F8N

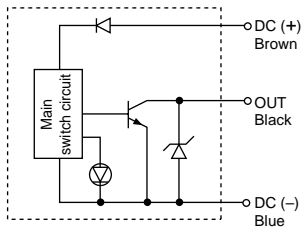

### D-F8P

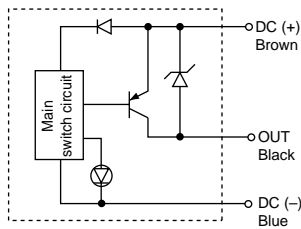

### D-F8B

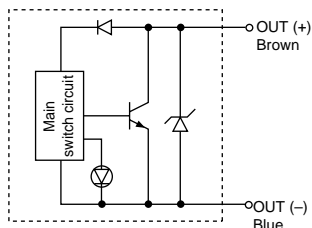

## Auto Switch Weights

Unit: g

Model		D-F8N	D-F8P	D-F8B
Lead wire length (m)	0.5	7	7	7
	3	32	32	32
	5	52	52	52

## Auto Switch Dimensions

### D-F8N, D-F8P, D-F8B

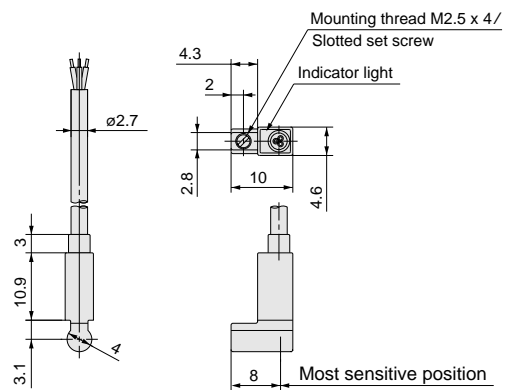

# Solid State Switches/Direct Mount Type D-F9N(V), D-F9P(V), D-F9B(V)

## Grommet



### Caution

#### Operation Instructions

Be sure to use the attached fixing screws to secure the auto switch.  
Use of screws beyond the specified range can damage the switch.

## Auto Switch Specifications

D-F9□, D-F9□V (with indicator light)						
Auto switch part no.	D-F9N	D-F9NV	D-F9P	D-F9PV	D-F9B	D-F9BV
Electrical direction	In-line	Perpendicular	In-line	Perpendicular	In-line	Perpendicular
Wiring type	3-wire				2-wire	
Output type	NPN		PNP		—	
Applicable load	IC circuit, Relay, PLC				DC24V relay, PLC	
Power supply voltage	5, 12, 24VDC (4.5 to 28V)				—	
Current consumption	10mA or less				—	
Load voltage	28VDC or less		—		24VDC (10 to 28V)	
Load current	40mA or less		80mA or less		5 to 40mA	
Internal voltage drop	1.5V or less (0.8V or less at 10mA load current)		0.8V or less		4V or less	
Leakage current	100μA or less at 24VDC				0.8mA or less	
Indicator light	Red LED lights when ON					

●Lead wire — Oil proof heavy duty vinyl cable,  $\phi 2.7$ , 3 cores (brown, black, blue), 0.15mm<sup>2</sup>, 2 cores (brown, blue), 0.18mm<sup>2</sup>, 0.5m

Note 1) Refer to page 14 for solid state switch common specifications.

Note 2) Refer to page 14 for lead wire lengths.

## Auto Switch Weights

Unit: g

Model		D-F9N(V)	D-F9P(V)	D-F9B(V)
Lead wire length (m)	0.5	7	7	6
	3	37	37	31
	5	61	61	51

## Auto Switch Internal Circuits

### D-F9N, F9NV

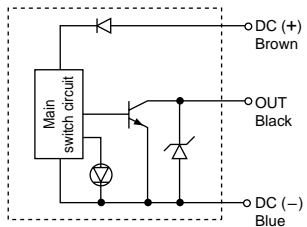

### D-F9P, F9PV

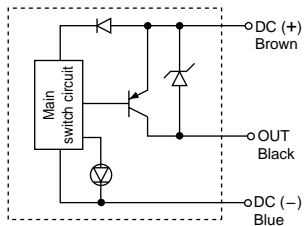

### D-F9B, F9BV

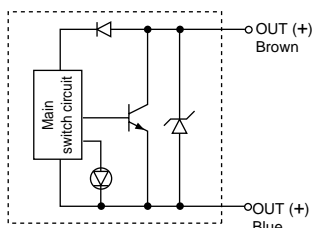

## Auto Switch Dimensions

### D-F9□

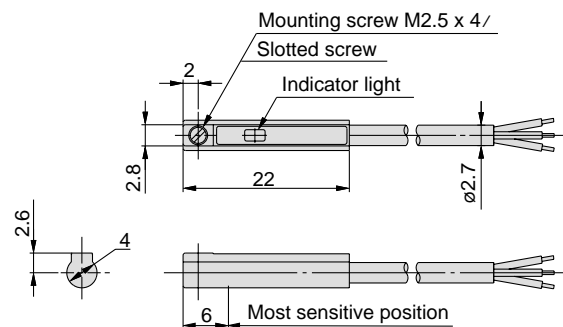

### D-F9□V

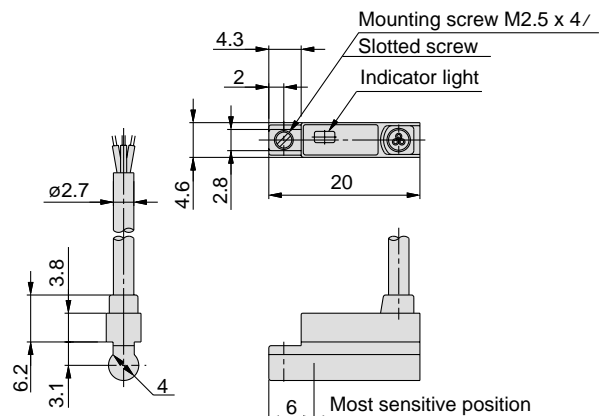

# 2-Color Display Solid State Auto Switches/Direct Mount Type D-F9NW(V), D-F9PW(V), D-F9BW(V)

## Auto Switch Specifications

### Grommet



D-F9□W, D-F9□WV (with indicator light)						
Auto switch part no.	D-F9NW	D-F9NWV	D-F9PW	D-F9PWV	D-F9BW	D-F9BWV
Electrical entry direction	In-line	Perpendicular	In-line	Perpendicular	In-line	Perpendicular
Wiring type	3-wire			2-wire		
Output type	NPN		PNP		—	
Applicable load	IC circuit, Relay IC, PLC				24VDC, Relay, PLC	
Power supply voltage	5, 12, 24VDC (4.5 to 28V)				—	
Current consumption	10mA or less				—	
Load voltage	28VDC or less		—		24VDC (10 to 28V)	
Load current	40mA or less		80mA or less		5 to 40mA	
Internal voltage drop	1.5V or less (0.8V or less at 10mA load current)		0.8V or less		4V or less	
Leakage current	100μA or less at 24VDC				0.8mA or less	
Indicator light	Operating position ··········· Red LED lights up Optimum operating position ········· Green LED lights up					

●Lead wire — Oil proof heavy duty vinyl cable,  $\phi 2.7$ , 3 cores (brown, black, blue), 0.15mm<sup>2</sup>, 2 cores (brown, blue), 0.18mm<sup>2</sup>, 0.5m

Note 1) Refer to page 14 for solid state switch common specifications.

Note 2) Refer to page 14 for lead wire length.

### Auto Switch Internal Circuits

#### D-F9NW, F9NWV

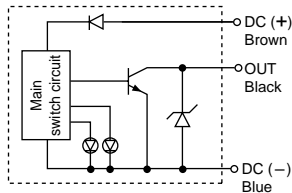

#### D-F9PW, F9PWV

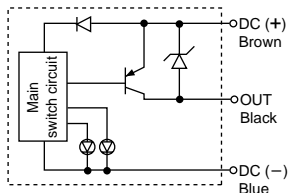

#### D-F9BW, F9BWV

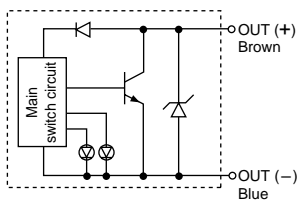

### Indicator light/Display method

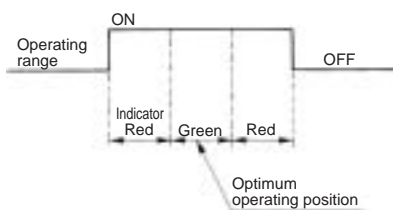

### Auto Switch Weights

Unit : g

Model		D-F9NW(V)	D-F9PW(V)	D-F9BW(V)
Lead wire length (m)	0.5	7	7	7
	3	34	34	32
	5	56	56	52

### Auto Switch Dimensions

#### D-F9□W

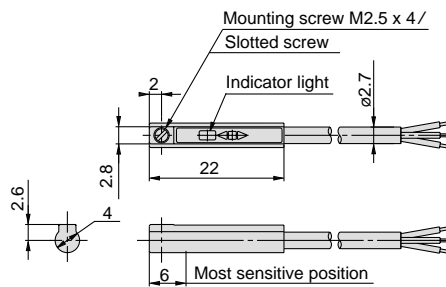

#### D-F9□WV

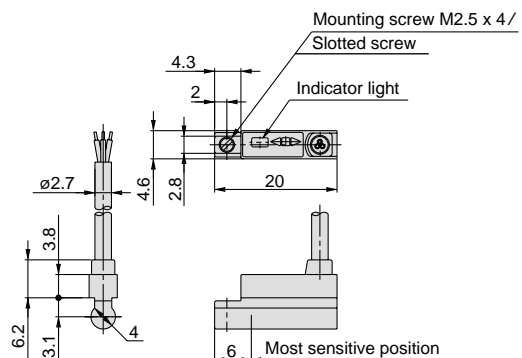

## Solid-state Auto Switches for Direct Mounting Series D-M9N(V)/D-M9P(V)/D-M9B(V)



### Grommet

- Reduced load currents for two-wire model (2.5 to 40 mA)
- Compliance with lead-free requirements
- Use of UL-approved lead wires (style 2844)



### Internal circuits

#### D-M9N/M9NV

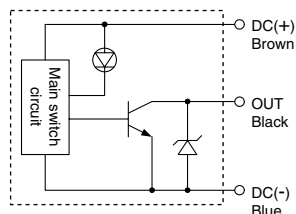

#### D-M9P/M9PV

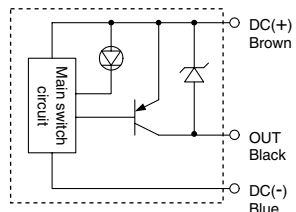

#### D-M9B/M9BV

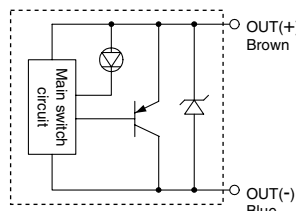

### Auto Switch Specifications

PLC: Programmable Logic Controller

D-M9□/D-M9□V (with Indicator light)						
Model number	D-M9N	D-M9NV	D-M9P	D-M9PV	D-M9B	D-M9BV
Electrical entry	In-line	Perpendicular	In-line	Perpendicular	In-line	Perpendicular
Wiring	Three-wire			Two-wire		
Output	NPN		PNP		—	
Applicable load	Integrated circuit, relay and PLC				24 V DC relay and PLC	
Power voltage	5, 12, or 24 V DC (4.5 to 28 V DC)				—	
Current consumption	10 mA or less				—	
Load voltage	28 V DC or less		—		24 V DC (10 to 28 V DC)	
Load current	40 mA or less				2.5 to 40 mA	
Internal voltage drop	0.8 V or less				4 V or less	
Leakage current	100 μA max. at 24 V DC				0.8 mA or less	
Indicator light	Red LED lights when ON.					

- Lead wire: oil-proof heavy-duty vinyl cable  
 2.7 x 3.2 with elliptic cross-section, 0.15 mm<sup>2</sup>, two cores (D-M9B),  
 or three cores (D-M9N and D-M9P)

### Solid state switch specifications

Leakage current	3-wire: 100 μA or less; 2-wire: 0.8 mA max.
Operating time	1 ms or less
Impact resistance	1000 m/s <sup>2</sup>
Insulation resistance	50 MΩ or more at 500 V DC (between lead wire and case)
Withstand voltage	1000 V AC for 1 min. (between lead wire and case)
Ambient temperature	-10°C to 60°C
Enclosure	IEC529 standard IP67, JIS C 0920 watertight construction

### Weight

Unit: g

Model	D-M9N(V)	D-M9P(V)	D-M9B(V)
Lead wire length (m)	0.5	8	7
	3	41	38
	5	68	63

### How to Order

#### Standard Model Number

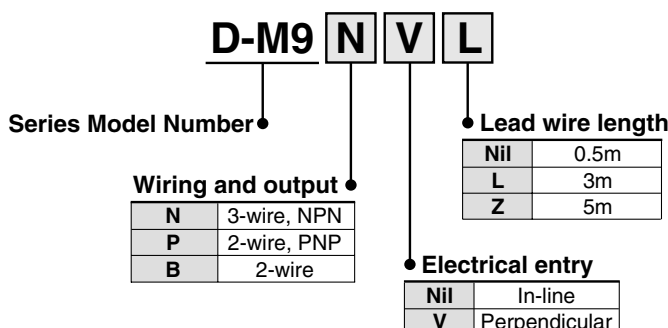

# Series D-M9

## Auto Switch Dimensions

### D-M9□

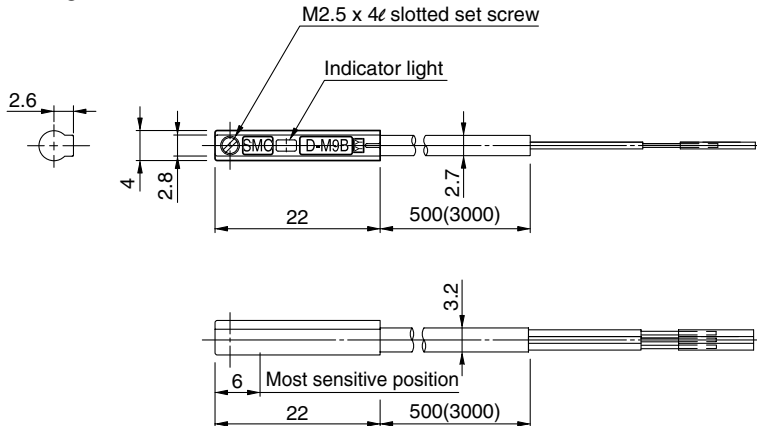

### D-M9□V

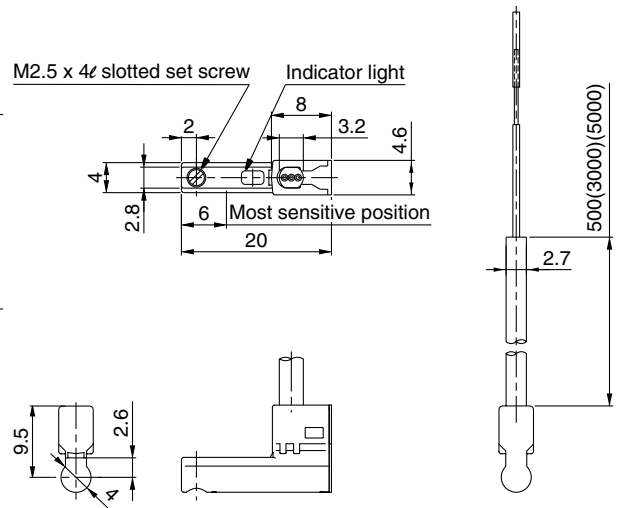

## ⚠ Specific Product Precautions

Be sure to read before handling. Contact SMC when the required specification is out of range.

### Handling

## ⚠ Caution

Observe the following precautions when handling the product.

- The D-M9 series of auto switches is not overcurrent-protected. Faulty wiring or short circuit may result in breakage or burning-out of the switch.
- When stripping the cable clad, be careful about the orientation of the cable being stripped. The insulator may be accidentally torn or damaged depending on the orientation, as shown on the right.

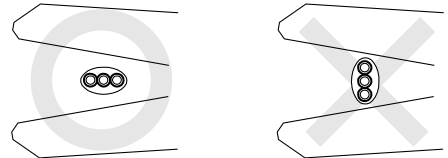

- We recommend the following tools

Manufacturer	Product name	Product number
VESSEL	Wire stripper	No 3000G
Tokyo Ideal	Strip master	45-089

\* The stripper for the round shape cords (ø2.0) is for a 2-wire style.

- Please do not attach the switch with any other screws than those already attached to the auto switch body.

## The operation range is shorter than that of the conventional models.

If the auto switch replaces the conventional model, it may not function depending on its application because the operation range is shorter. Refer to the examples below.

- In an application where at the end, the stopping position shifting range is larger than the operation range. For example, pushing a work against something, or pressing a work into a hole, or clamping a work.
- In an application where the auto switch is used to detect an intermediate stopping position. (Detecting time is shortened.)

Note) Please contact SMC for the operation range details for each actuator.

The switch is damaged instantly when a load is shortened since short circuit protection is not built-in. Pay special attention to avoid reversing the connection of the brown lead of the power supply line and the black output line connection.







Series *MIW/MIS*

# Safety Instructions

These safety instructions are intended to prevent a hazardous situation and/or equipment damage. These instructions indicate the level of potential hazard by a label of "**Caution**", "**Warning**" or "**Danger**". To ensure safety, be sure to observe ISO 4414 Note 1), JIS B 8370 Note 2) and other safety practices.

 **Caution** : Operator error could result in injury or equipment damage.

 **Warning** : Operator error could result in serious injury or loss of life.

 **Danger** : In extreme conditions, there is a possible result of serious injury or loss of life.

Note 1) ISO 4414: Pneumatic fluid power — Recommendations for the application of equipment to transmission and control systems

Note 2) JIS B 8370: General Rules for Pneumatic Equipment

## Warning

### **1. The compatibility of pneumatic equipment is the responsibility of the person who designs the pneumatic system or decides its specifications.**

Since the products specified here are used in various operating conditions, their compatibility for the specific pneumatic system must be based on specifications or after analysis and/or tests to meet your specific requirements.

### **2. Only trained personnel should operate pneumatically operated machinery and equipment.**

Compressed air can be dangerous if handled incorrectly. Assembly, handling or repair of pneumatic systems should be performed by trained and experienced operators.

### **3. Do not service machinery/equipment or attempt to remove components until safety is confirmed.**

1. Inspection and maintenance of machinery/equipment should only be performed after confirmation of safe locked-out control positions.

2. When equipment is to be removed, confirm the safety process as mentioned above. Cut the supply pressure for this equipment and exhaust all residual compressed air in the system.

3. Before machinery/equipment is restarted, take measures to prevent shooting-out of cylinder piston rod, etc. (Bleed air into the system gradually to create back pressure.)

### **4. Contact SMC if the product is to be used in any of the following conditions:**

1. Conditions and environments beyond the given specifications, or if product is used outdoors.

2. Installation on equipment in conjunction with atomic energy, railway, air navigation, vehicles, medical equipment, food and beverages, recreation equipment, emergency stop circuits, press applications, or safety equipment.

3. An application which has the possibility of having negative effects on people, property, or animals, requiring special safety analysis.



# Series MIW/MIS Actuator Precautions 1

Be sure to read before handling.

## Design

### ⚠ Warning

1. **There is a danger of sudden action by air cylinders if sliding parts of machinery are twisted, etc., and changes in forces occur.**

In such cases, human injury may occur; e.g., by catching hands or feet in the machinery, or damage to the machinery itself may occur. Therefore, the machine should be designed to avoid such dangers.

2. **A protective cover is recommended to minimize the risk of human injury.**

If a driven object and moving parts of a cylinder pose a danger of human injury, design the structure to avoid contact with the human body.

3. **Securely tighten all stationary parts and connected parts so that they will not become loose.**

Especially when a cylinder operates with high frequency or is installed where there is a lot of vibration, ensure that all parts remain secure.

4. **A deceleration circuit or shock absorber may be required.**

When a driven object is operated at high speed or the load is heavy, a cylinder's cushion will not be sufficient to absorb the impact. Install a deceleration circuit to reduce the speed before cushioning, or install an external shock absorber to relieve the impact. In this case, the rigidity of the machinery should also be examined.

5. **Consider a possible drop in circuit pressure due to a power outage, etc.**

When a cylinder is used in a clamping mechanism, there is a danger of work pieces dropping if there is a decrease in clamping force due to a drop in circuit pressure caused by a power outage, etc. Therefore, safety equipment should be installed to prevent damage to machinery and human injury. Suspension mechanisms and lifting devices also require consideration for drop prevention.

6. **Consider a possible loss of power source.**

Measures should be taken to protect against human injury and equipment damage in the event that there is a loss of power to equipment controlled by pneumatics, electricity or hydraulics, etc.

7. **Design circuitry to prevent sudden lurching of driven objects.**

When a cylinder is driven by an exhaust center type directional control valve or when starting up after residual pressure is exhausted from the circuit, etc., the piston and its driven object will lurch at high speed if pressure is applied to one side of the cylinder because of the absence of air pressure inside the cylinder. Therefore, equipment should be selected and circuits designed to prevent sudden lurching, because there is a danger of human injury and/or damage to equipment when this occurs.

8. **Consider emergency stops.**

Design so that human injury and/or damage to machinery and equipment will not be caused when machinery is stopped by a safety device under abnormal conditions, such as a power outage or a manual emergency stop.

9. **Consider the action when operation is restarted after an emergency stop or abnormal stop.**

Design the machinery so that human injury or equipment damage will not occur upon restart of operation.

When the cylinder has to be reset at the starting position, install safe manual control equipment.

## Selection

### ⚠ Warning

1. **Confirm the specifications.**

The products included in this catalog are designed according to use in industrial compressed air systems. If the products are used in conditions where pressure and/or temperature are out of specification, damage and/or malfunction may be caused. Do not use in these conditions. (Refer to specifications.)

Consult SMC if you use a fluid other than compressed air.

2. **Intermediate stops**

When intermediate stopping of a cylinder piston is performed with a 3 position closed center type directional control valve, it is difficult to achieve stopping positions as accurate and precise as with hydraulic pressure due to the compressibility of air.

Furthermore, since valves and cylinders are not guaranteed for zero air leakage, it may not be possible to hold a stopped position for an extended period of time. Contact SMC in case it is necessary to hold a stopped position for an extended period.

### ⚠ Caution

1. **Use a speed controller to adjust the cylinder drive speed, gradually increasing from a low speed to the desired speed setting.**

## Mounting

### ⚠ Caution

1. **Do not use until you verify that equipment can operate properly.**

Following mounting, repair or conversions, verify correct mounting by suitable function and leakage tests after compressed air and power are connected.

2. **Instruction manual**

The product should be mounted and operated after thoroughly reading the manual and understanding its contents.

Keep the instruction manual where it can be referred to as needed.

## Piping

### ⚠ Caution

1. **Preparation before piping**

Before piping is connected, it should be thoroughly blown out with air (flushing) or washed to remove chips, cutting oil and other debris from inside the pipe.

2. **Wrapping of sealant tape**

When screwing together pipes and fittings, etc., be certain that chips from the pipe threads and sealing material do not get inside the piping.

Also, when sealant tape is used, leave 1.5 to 2 thread ridges exposed at the end of the threads.

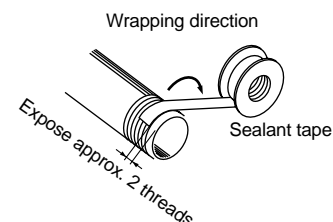



# Series MIW/MIS Actuator Precautions 2

Be sure to read before handling.

## Lubrication

### ⚠ Caution

#### 1. Lubrication of non-lube type cylinder

The cylinder is lubricated at the factory and can be used without any further lubrication.

However, in the event that it will be lubricated, use class 1 turbine oil (with no additives) ISO VG32.

Stopping lubrication later may lead to malfunction due to the loss of the original lubricant. Therefore, lubrication must be continued once it has been started.

## Air Supply

### ⚠ Warning

#### 1. Use clean air.

Do not use compressed air that includes chemicals, synthetic oils containing organic solvents, salt or corrosive gases, etc., as it can cause damage or malfunction.

### ⚠ Caution

#### 1. Install air filters.

Install air filters at the upstream side of valves. The filtration degree should be 5 μm or finer.

#### 2. Install an air dryer, after-cooler or water separator, etc.

Air that includes excessive drainage may cause malfunction of valves and other pneumatic equipment. To prevent this, install an air dryer, after-cooler or water separator, etc.

#### 3. Use the product within the specified range of fluid and ambient temperature.

At temperatures of 5°C or lower, take measures to prevent freezing, since moisture in circuits may be frozen and this can cause damage to seals and lead to malfunction.

Refer to SMC's "Best Pneumatics vol. 4" catalog for further details on compressed air quality.

## Operating Environment

### ⚠ Warning

#### 1. Do not use in environments where there is a danger of corrosion.

Refer to the construction drawings regarding cylinder materials.

#### 2. In dusty locations or where water or oil splash on the equipment, install a protective cover over the rod.

#### 3. When using auto switches, do not operate in an environment with strong magnetic fields.

## Maintenance

### ⚠ Warning

#### 1. Perform maintenance according to the procedure indicated in the instruction manual.

If handled improperly, malfunction and damage of machinery or equipment may occur.

#### 2. Removal of equipment, and supply/exhaust of compressed air

When machinery is removed, first check measures to prevent dropping of driven objects and run-away of equipment, etc. Then cut off the supply pressure and electric power, and exhaust all compressed air from the system.

When machinery is restarted, proceed with caution after confirming measures to prevent cylinder lurching.

### ⚠ Caution

#### 1. Drain flushing

Drain air filters regularly.



# Series MIW/MIS

## Specific Product Precautions 1

Be sure to read before handling.

Refer to pages 16 through 18 for safety instructions, actuator precautions and auto switch precautions.

### Selection

#### Warning

##### 1. Design the attachment to be light and short.

- 1) A long and heavy attachment can cause a large inertia force in operation, sometimes affecting the life time.
- 2) Design the attachment to be as short and light as possible even within the limitation.

### Mounting

#### Warning

##### 1. Do not scratch or gouge the escapement by dropping or bumping it when mounting.

Even a slight deformation can cause inaccuracy or malfunction.

##### 2. Please observe the specified torque limits when tightening screws to mount the attachment.

A tightening torque beyond the specified limits can cause malfunction, while a tightening torque below the specified limits can cause dislocation or drop off.

### Mounting attachment on finger

When mounting an attachment on the finger, support the finger with a tool like a spanner to prevent twisting.

Mount attachments by inserting bolts, etc. into the female mounting threads on the fingers and tightening with the torque shown in the table below.

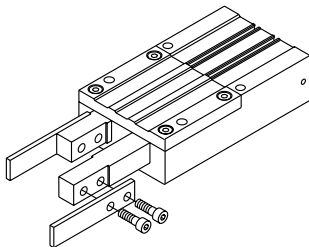

Model	Bolt	Max tightening torque N·m
MIW12D-12D	M3 x 0.5	0.88
MIS12D-□□D		
MIW20D-20D	M5 x 0.8	4.3
MIS20D-□□D		

### Mounting

##### 3. Please observe the specified torque limits when tightening screws to mount the attachment.

A tightening torque above the specified limits can cause malfunction, while a tightening torque below the specified limits can cause dislocation or drop off.

#### Mounting

##### Body tap

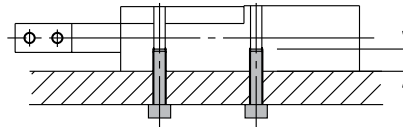

Model	Bolt	Max tightening torque N·m	Max screw-in depth (mm)
MIW12D-12D	M4 x 0.7	1.6	6
MIS12D-□□D			
MIW20D-20D	M6 x 1	5.4	9
MIS20D-□□D			

##### Body through hole

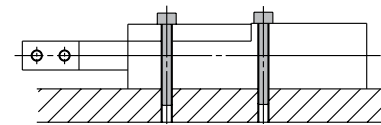

Model	Bolt	Max tightening torque N·m
MIW12D-12D	M3 x 0.5	0.88
MIS12D-□□D		
MIW20D-20D	M5 x 0.8	4.3
MIS20D-□□D		

#### Caution

##### 1. When mounting an attachment on the finger, support the finger with a tool like a spanner to prevent twisting.

Otherwise malfunction may result.

##### 2. Please do not scratch or gouge the sliding part of the finger.

It may increase the sliding resistance or cause abrasion.

##### 3. Use a speed controller, etc. to keep the operating speed of the finger within the proper range.

Otherwise the life time may be adversely affected by inertia force of the attachment.

##### 4. Conduct meter-out control to throttle down the speed.

Applicable speed controller  
 Direct connection type — AS1200-M5  
 Piping type — AS1001F  
 Piping type — AS2001F etc.

### Handling of Adjuster Options

#### Stroke adjuster

#### Caution

##### 1. Be sure to use specified adjuster bolts for replacement.

Otherwise, fracture may be caused by an impact.

##### 2. Refer to the table below for the lock nut tightening torque.

Insufficient tightening can cause air leakage.

Model	Tightening torque N·m
MIS12	3.0
MIW12	
MIS20	12.5
MIW20	

##### 3. Adjust the stroke adjuster within the range below.

Using the product beyond the specified range can cause malfunction in sequential operation or dropping of bolts.

Model	At the maximum stroke (mm)	At the maximum adjustment (mm)	Adjustment range (mm)
MIS12	14	8	6
MIW12			
MIS20	22.5	10.5	12
MIW20			

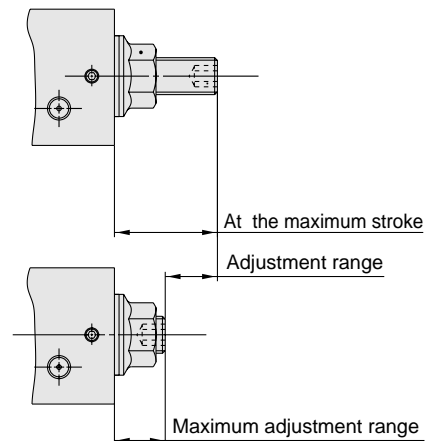



# Series MIW/MIS

## Specific Product Precautions 2

Be sure to read before handling.

Refer to pages 16 through 18 for safety instructions, actuator precautions and auto switch precautions.

### Operating Environment

#### ⚠ Caution

- Do not use in an environment where the product is directly exposed to liquid such as cutting lubricant.**  
Avoid use in an environment where the product is exposed to cutting lubricant, liquid coolant or oil mist. It can cause rattles, increase in sliding resistance and air leakage.
- Do not use in an environment where the product is directly exposed to foreign matter such as dust, coarse particular, chips and polishing powder from a spatter grinder, etc.**  
It can cause rattles, increase in sliding resistance and air leakage.
- Provide shading in an environment where the product is exposed to the sunlight.**
- Block off heat radiation in an environment where a heat source is at a close distance.**  
Block off heat radiation with a cover if a heat source is at a close distance because the temperature of the product can rise to exceed the operating temperature range due to radiation.
- Do not use in an environment where vibration or impact occurs.**  
Contact SMC about use under such conditions because it can cause fracture or malfunction.

### Lubrication

#### ⚠ Caution

- The non-lubricant type escapement is lubricated at the factory and does not need further lubrication for use.**  
In case the product is lubricated by the customer, apply class 1 turbin oil (non additive) ISO VG32.  
In case the product is lubricated by the customer, be sure to continue lubrication.  
If it is discontinued, malfunction may result due to loss of initial lubricant.

### Maintenance

#### ⚠ Warning

- Keep away hands and other body parts from the fingers of the escapement or movement range of the attachment.**  
It can lead to an injury or accident.
- When removing the escapement, first block off or remove the work piece on the primary side of the escapement and extract the compressed air.**  
If the work piece remains, it can be transferred by mistake and cause failure to the equipment on the secondary side.

#### Finger replacement

- Remove the hexagon socket head screws.**
- Remove the cover.**
- Replace the finger.**
  - Apply the specified grease to the sliding part and T groove part of the finger.
  - Insert the piston in the T groove so that it will be hooked there.
- Mount the cover and tighten the hexagon socket head screws with the tightening torque in the table below.**

#### Hexagon socket head screw

	Size	Width across flats	Tightening torque N·m
ø12	M2.5 x 6	2	0.36
ø20	M4 x 10	3	1.5

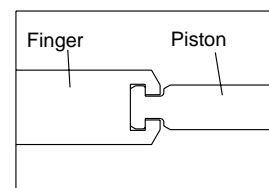
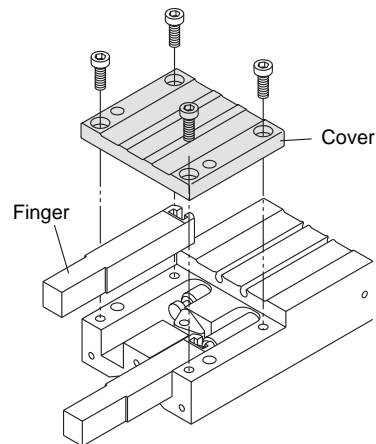

For information on the replacement parts and specified grease, refer to the replacement parts on page 3.



## SMC'S GLOBAL MANUFACTURING, DISTRIBUTION AND SERVICE NETWORK

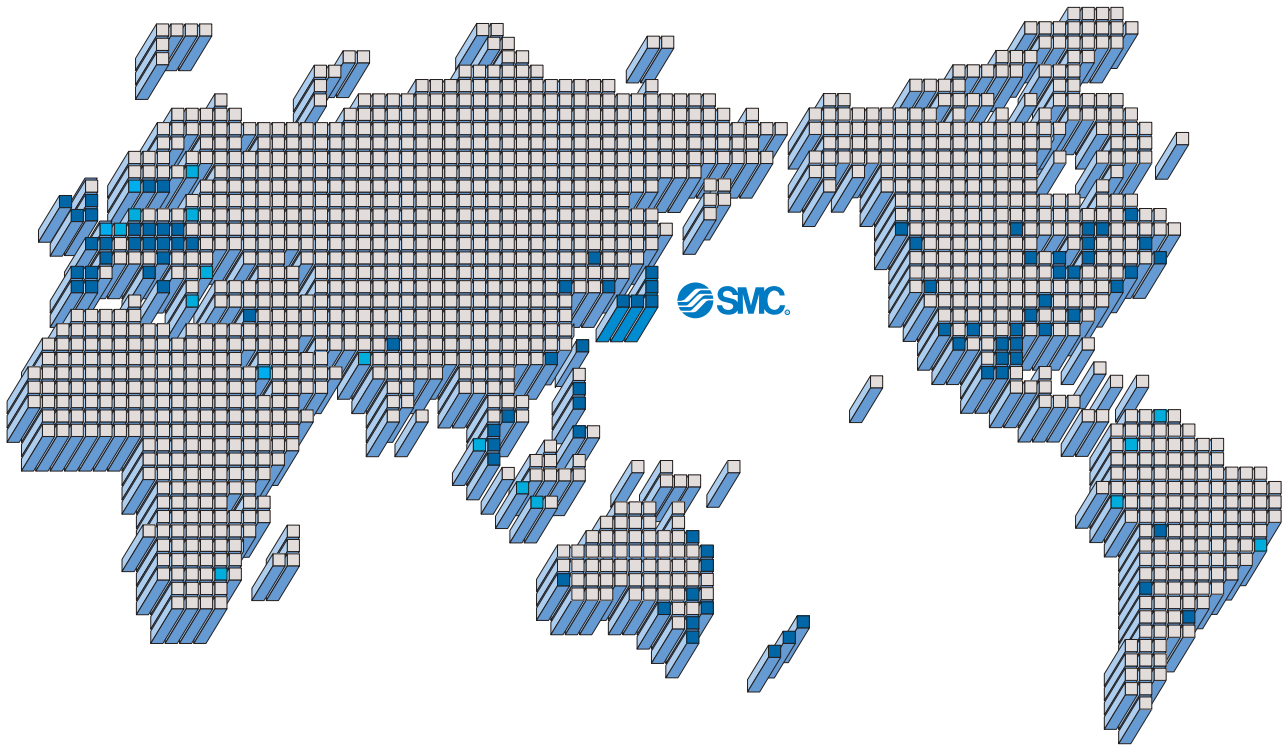

### EUROPE

#### AUSTRIA

SMC Pneumatik GmbH

#### CZECH

SMC Industrial Automation CZ s.r.o.

#### DENMARK

SMC Pneumatik A/S

#### FINLAND

SMC Pneumatics Finland OY

#### FRANCE

SMC Pneumatique SA

#### GERMANY

SMC Pneumatik GmbH

#### HUNGARY

SMC Hungary Ipari Automatizálási Kft.

#### IRELAND

SMC Pneumatics (Ireland) Ltd.

#### ITALY

SMC Italia S.p.A.

#### LATVIA

SMC Pneumatics Latvia SIA

#### NETHERLANDS

SMC Pneumatics BV.

#### NORWAY

SMC Pneumatics Norway A/S

#### POLAND

SMC Industrial Automation Polska Sp.z.o.o.

#### ROMANIA

SMC Romania s.r.l.

#### RUSSIA

SMC Pneumatik LLC.

### EUROPE

#### SLOVAKIA

SMC Priemyselná Automatizácia, s.r.o.

#### SLOVENIA

SMC Industrijska Avtomatika d.o.o.

#### SPAIN/PORTUGAL

SMC España, S.A.

#### SWEDEN

SMC Pneumatics Sweden AB

#### SWITZERLAND

SMC Pneumatik AG.

#### UK

SMC Pneumatics (U.K.) Ltd.

### ASIA

#### CHINA

SMC (China) Co., Ltd.

#### HONG KONG

SMC Pneumatics (Hong Kong) Ltd.

#### INDIA

SMC Pneumatics (India) Pvt. Ltd.

#### MALAYSIA

SMC Pneumatics (S.E.A.) Sdn. Bhd.

#### PHILIPPINES

SMC Pneumatics (Philippines), Inc.

#### SINGAPORE

SMC Pneumatics (S.E.A.) Pte. Ltd.

#### SOUTH KOREA

SMC Pneumatics Korea Co., Ltd.

#### TAIWAN

SMC Pneumatics (Taiwan) Co., Ltd.

### ASIA

#### THAILAND

SMC Thailand Ltd.

### NORTH AMERICA

#### CANADA

SMC Pneumatics (Canada) Ltd.

#### MEXICO

SMC Corporation (Mexico) S.A. de C.V.

#### USA

SMC Corporation of America

### SOUTH AMERICA

#### ARGENTINA

SMC Argentina S.A.

#### BOLIVIA

SMC Pneumatics Bolivia S.R.L.

#### BRAZIL

SMC Pneumaticos Do Brazil Ltda.

#### CHILE

SMC Pneumatics (Chile) S.A.

#### VENEZUELA

SMC Neumatica Venezuela S.A.

### OCEANIA

#### AUSTRALIA

SMC Pneumatics (Australia) Pty. Ltd.

#### NEW ZEALAND

SMC Pneumatics (N.Z.) Ltd.

## SMC Corporation

1-16-4 Shimbashi, Minato-ku, Tokyo 105-0004, JAPAN

Tel: 03-3502-2740 Fax: 03-3508-2480

URL <http://www.smcworld.com>

© 2002 SMC Corporation All Rights Reserved

1st printing February, 2002 D-DAD P-80 (D)

This catalog is printed on recycled paper with concern for the global environment.

Specifications are subject to change without prior notice and any obligation on the part of the manufacturer.

Printed in Japan.